



## PECVD WAFER BOAT ASSEMBLIES

*Quality graphite components to fit batch PECVD systems*

### Overview

Graphite wafer plates perform an important function as an electrically conductive substrate support, sustaining a plasma during the deposition of the critical nitride layer of a solar cell. The uniformity of this plasma enhanced deposition impacts the quality of the cells being produced and ultimately their overall efficiency.

To address this need for uniformity POCO offers graphite plate assemblies produced from PVL isotropic, fine-grain graphite. Strong, yet flexible due to a highly uniform microstructure, PVL plates will consistently provide reliable wafer support throughout multiple process cycles. In addition, PVL has a thermal expansion coefficient which closely matches that of the ceramic components used in the assembly resulting in reduced stress from thermal expansion mismatch.

#### Individual Wafer Plate Assemblies

Individual graphite plates include six wafer pockets per plate and wafer positioning pins already installed. For a 19 plate boat assembly, four unique plates are designed to fulfill all OEM plate replacements. Five unique plates are designed to fulfill all plate replacements for a 21 plate boat assembly. These standard plate assemblies may be ordered in any quantity as direct replacement parts for existing PECVD tools. If desired, custom plates can also be produced to customer specifications.

#### Complete Boat Assemblies

Full wafer boat assemblies containing either 19 individual plates or 21 individual plates are available fully assembled. These boats include all graphite and ceramic components and are ready for use as replacements or spares in the tool.



*PECVD graphite tray*

#### Optional Purification Available

PVL can also be provided as a purified material, then designated as PVL-2. If improved cell efficiency is a goal, removing metallic impurities from the graphite material prior to initial installation may be desirable. High-purity (less than 5 ppm impurities) components will eliminate one source of contamination from the start of the process. Typical wet or dry etching will remove surface contamination during required preventive maintenance. The purification option will add marginal cost and lead time to the graphite components.

#### Additional Wafer Boat Components

- 6 and 8 mm graphite rods in required lengths
- Cap nuts
- Connector blocks
- Connector nuts
- Spare pins
- Ceramic spacers\*
- Ceramic threaded rods\*

*\*These small components are subject to minimum total order requirements when ordered without plates but may be combined in any combination of parts.*

## 19 (DE-37706) and 21 (DE-37907) Plate PECVD Boat Assemblies

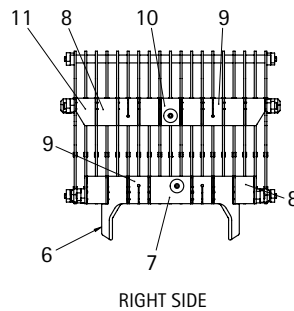
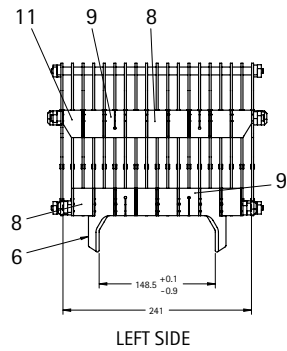
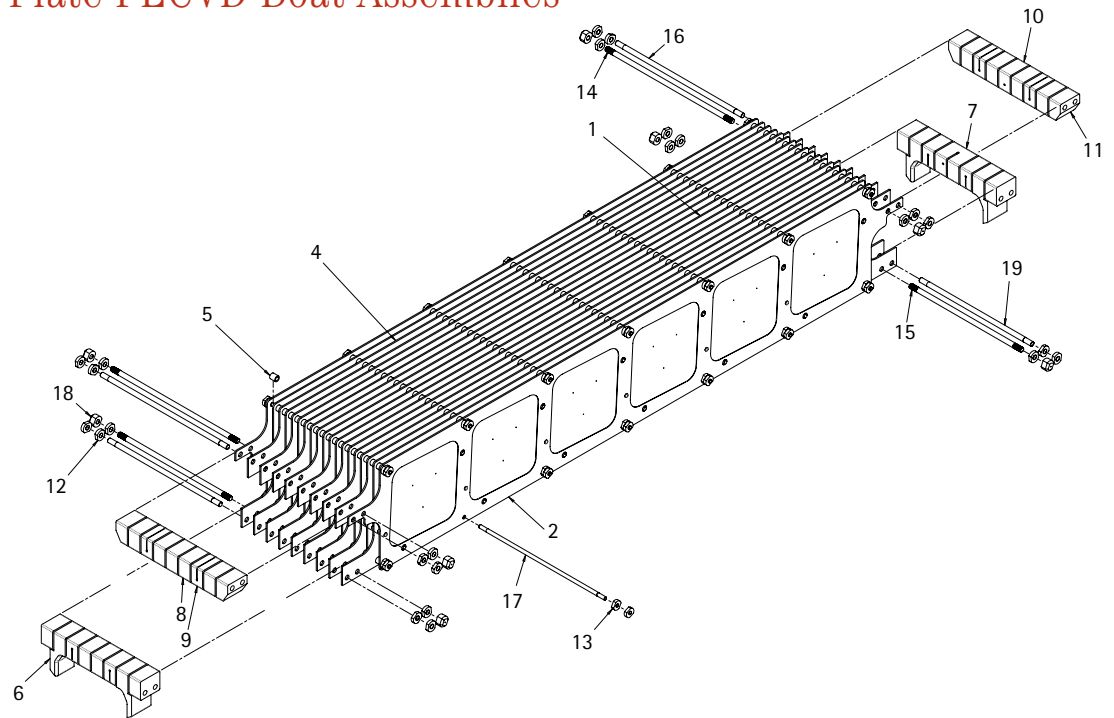

## Additional Views for 21 Plate Assembly

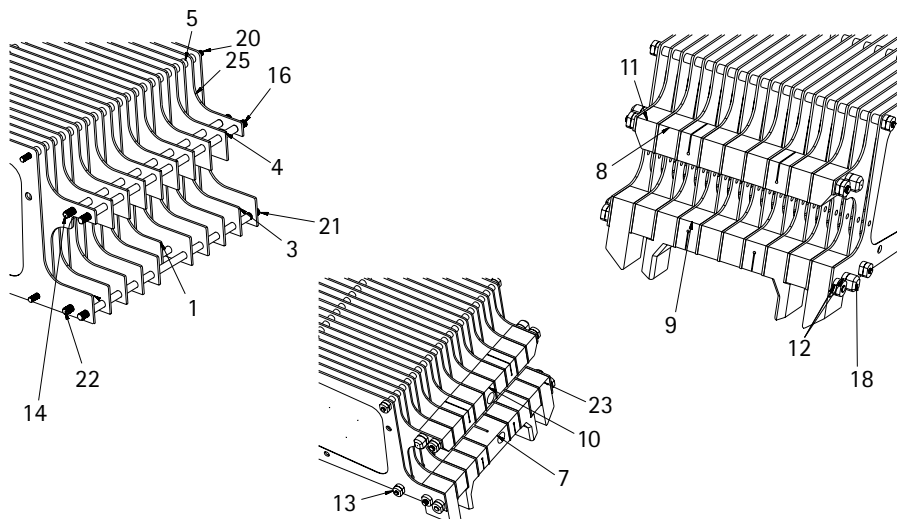

## PECVD Part Numbers

Location	Part Number	Required for Assembly		Description
		19 Plates	21 Plates	
*	DE-39415	X		19 plate full boat assembly
*	DE-39410		X	21 plate full boat assembly
1	DE-37018C	X	X	Graphite center mid plate assembly #1
2	DE-36761C	X		Graphite end plate assembly for 19 plate boat
3	DE-37014C	X	X	Graphite lower mid plate assembly
4	DE-37016C	X	X	Graphite upper mid plate assembly
5	DE-32720	X	X	Ceramic spacer Ø6 mm x 11 mm L
6	DE-32716	X	X	Graphite foot block #1
7	DE-32715	X	X	Graphite double expansion block
8	DE-32712	X	X	Graphite standard 11 mm block
9	DE-32713	X	X	Graphite expansion block
10	DE-32714	X	X	Graphite top connector block
11	DE-37710	X	X	Graphite angled connector block
12	DE-32718	X	X	Graphite nut 8 mm ID
13	DE-32717	X	X	Graphite nut 6 mm ID
14	DE-37004	X	X	Graphite threaded rod Ø8 mm x 272.5 mm L
15	DE-37003	X		Graphite threaded rod Ø8 mm x 241 mm L
16	DE-37708	X	X	Ceramic threaded rod Ø8 mm x 272.5 mm L
17	DE-37707	X		Ceramic threaded rod Ø6 mm x 271 mm L
18	DE-37005	X	X	Graphite cap nut 8 mm ID
19	DE-37709	X		Ceramic rod Ø8 mm x 241 mm L
20	DE-38076		X	Ceramic rod Ø6 mm x 298 mm L
21	DE-38077		X	Ceramic rod Ø8 mm x 295 mm L
22	DE-39409		X	Graphite threaded rod Ø8 mm x 295 mm L
23	DE-38079		X	Graphite foot block #2
24	DE-39367C		X	Graphite end plate assembly for 21 plate boat
25	DE-39368C		X	Graphite center mid plate assembly #2
*	DE-33230	X	X	Graphite pin X: 0.335 mm OD**
*	DE-33231	X	X	Graphite pin Y: 0.234 mm OD**

\* Not shown on diagram; pins are already mounted on plates. Part numbers are provided for replacement parts.

\*\* Wafer locating pins are installed in all plates as required to create "plate assemblies". Replacement pins are available from stock and can be combined with other spare components.

## Typical Material Properties

Property	PVL
Particle size	14 $\mu\text{m}$ (550 $\mu\text{in}$ )
Pore size <sup>1</sup>	1.2 $\mu\text{m}$ (47 $\mu\text{in}$ )
Coefficient of thermal expansion <sup>2</sup>	7.6 $\mu\text{m}/\text{m}^\circ\text{C}$ (4.22 $\mu\text{in}/\text{in}^\circ\text{F}$ )
Compressive strength	104 MPa (15,100 psi)
Flexural strength <sup>3</sup>	58 MPa (8392 psi)
Tensile strength <sup>4</sup>	38 MPa (5445 psi)
Shore hardness	66
Electrical resistivity	1300 $\mu\Omega\text{-cm}$ (512 $\mu\Omega\text{-in}$ )
Apparent density	1.69 $\text{g}/\text{cm}^3$ (0.061 $\text{lb}/\text{in}^3$ )
Thermal conductivity	40 $\text{Btu}\text{-ft}/\text{hr}/\text{ft}^2\text{ }^\circ\text{F}$ (70 $\text{W}/\text{m}\text{-K}$ )
Oxidation threshold <sup>5</sup>	475 $^\circ\text{C}$ (890 $^\circ\text{F}$ )

<sup>1</sup> Measured using Hg porosimetry method

<sup>2</sup> Average for temperature range of RT - 800 $^\circ\text{C}$

<sup>3</sup> Measured using 4-point bend method

<sup>4</sup> Estimated at 70% of flexural strength.

<sup>5</sup> Temperature that results in 1% wt. loss in 24 hrs. Oxidation threshold increases by approximately 100 $^\circ\text{C}$  if graphite is purified. Test sample size equals 0.5" x 0.5" x 1.0"

## For More Information

Please call your Regional Customer Service Center today to learn what POCO can do for you. Visit [www.poco.com](http://www.poco.com) and select the Contact Us link for the center nearest you.

POCO® is a registered trademark of Poco Graphite, Inc.

### POCO GRAPHITE, INC.

Corporate Headquarters | 300 Old Greenwood Rd. | Decatur, Texas 76234 USA  
 Telephone: 1.940.627.2121 | Facsimile: 1.940.393.8366  
[www.poco.com](http://www.poco.com)